

remarque que l'écart de l'atome de plomb par rapport au plan de symétrie de la cavité est trois fois plus important.

Le facteur d'agitation thermique calculé de l'atome Pb(10) est plus faible que celui des autres atomes de plomb. On peut en déduire que dans les cavités tétra-gonales, les atomes de plomb occupent toujours la même position par rapport aux atomes de niobium les plus proches, contrairement à ce que l'on observe dans les cavités pentagonales qui sont notablement plus grandes.

Dans la structure moyenne, une cavité tétra-gonale correspond à quatre cavités tétra-gonales indépendantes de la structure réelle. Dans l'ensemble, ces cavités sont occupées avec la probabilité $\frac{1}{2}$. Si dans la structure réelle, les cavités occupées sont ordonnées, une cavité tétra-gonale de la structure moyenne contiendra en fait 2 positions occupées avec la probabilité $\frac{1}{4}$. L'effet de moyenne aura alors moins d'influence sur le facteur d'agitation thermique calculé.

Les résultats obtenus avec le cristal maclé et l'échan-tillon dépourvu de domaine à 90° sont concordants. Ils permettent de résoudre la structure moyenne de PbNb₂O₆ orthorhombique en admettant que les atomes ont une cote z égale à 0 ou $\frac{1}{2}$. L'arrangement des atomes de niobium a été déterminé avec une bonne précision et semble être peu différent dans la structure moyenne et dans la structure réelle. Les cavités pentagonales sont toujours occupées par un atome de plomb décalé par rapport au centre dans la direction de l'axe ferro-électrique, alors que les cavités tétra-gonales sont occu-pées par un atome situé en leur centre.

Nous avons montré que la différence entre la densité électronique moyenne et la densité électronique réelle n'est importante que dans les cavités occupées par les atomes de plomb. Ces variations peuvent provenir

d'une mise en ordre des cavités tétra-gonales occupées ou des corrélations entre les déplacements réels des atomes à l'intérieur des cavités pentagonales. La déter-mination de la structure réelle de PbNb₂O₆ nécessite l'utilisation des réflexions de surstructure et est rendue délicate du fait de la très faible intensité de ces réflexions.

Nous remercions MM Desgardin & Raveau du Groupe de Cristallographie et Chimie du Solide de Caen pour la préparation des cristaux et les fructueuses discussions relatives à cette étude.

Références

- ABRAHAMS, S. C., KURTZ, S. K. & JAMIESON, P. B. (1968). *Phys. Rev.* **172**, 551-553.
 BRUSSET, H., GILLIER-PANDRAUD, H. & MAHÉ, R. (1970). *C.R. Acad. Sci. Paris*, **270**, 302-305.
 CROMER, D. T. (1965). *Acta Cryst.* **18**, 17-23.
 CROMER, D. T. & WABER, J. T. (1965). *Acta Cryst.* **18**, 104-109.
 CRICKSHANK, D. W. J. (1960). *Acta Cryst.* **13**, 774-777.
 FRANCOMBE, M. H. (1956). *Acta Cryst.* **9**, 683-684.
 FRANCOMBE, M. H. & LEWIS, B. (1958). *Acta Cryst.* **11**, 696-703.
 GASPERIN, M. (1964). *Bull. Soc. Fr. Minér. Crist.* **87**, 50-52.
 GOODMAN, G. (1953). *J. Amer. Ceram. Soc.* **36**, 368-372.
 HERBSTEIN, F. H. & KAPON, M. (1971). *Acta Cryst.* **A27**, 244-245.
 JAMIESON, P. B., ABRAHAMS, S. C. & BERNSTEIN, J. L. (1968). *J. Chem. Phys.* **48**, 5048-5057.
 JAMIESON, P. B., ABRAHAMS, S. C. & BERNSTEIN, J. L. (1969). *J. Chem. Phys.* **50**, 4352-63.
 MAGNÉLI, A. (1949). *Ark. Kem.* **1**, 213.
 PREWITT, C. T. (1966). *SFLS-5*. Report ORNL-TM-305, Oak Ridge National Laboratory, Oak Ridge, Tennessee.
 ROTH, R. S. (1957). *Acta Cryst.* **10**, 437.

Acta Cryst. (1973). **B29**, 2210

9 α -Bromocortisol, a Weak Cortisol Derivative

BY CHARLES M. WEEKS AND WILLIAM L. DUAX

Medical Foundation of Buffalo, 73 High Street, Buffalo, New York 14203, U.S.A.

(Received 14 February 1973; accepted 3 April 1973)

9 α -Bromocortisol (C₂₁H₂₉BrO₃) is hexagonal, space group $P6_5$, $a = 7.377$ (8), $c = 61.23$ (6) Å, $Z = 6$, $M = 441.38$, $D_c = 1.52$ g cm⁻³ and $D_m = 1.50$ g cm⁻³ (by flotation). The A-ring orientation resembles that seen in cortisol and differs from the orientation observed in 9 α -fluorocortisol. This conformational feature may be correlated with glucocorticoid activity.

Introduction

As part of a multidisciplinary investigation of steroid molecular structure and function involving synthesis, pharmacological testing (Zanati & Wolff,

1971), crystal structure determination (Weeks, Duax & Wolff, 1973), solution spectral analysis, and theoretical energy calculations (Kollman, Giannini, Duax, Rothenberg & Wolff, 1973), the crystal structure of 9 α -bromocortisol was solved from the three-

dimensional X-ray diffraction data by a routine application of the heavy-atom method. The systematic absences (000*l*; *l*=6*n*) in the diffraction pattern of 9 α -bromocortisol were consistent with the enantiomorphous hexagonal space groups $P6_1$ and $P6_5$, and space group $P6_3$ (C_3^2 , No. 170) was chosen after the complete X-ray analysis revealed that the enantiomorph occurring in this space group had the absolute configuration known to be correct on account of the method of chemical synthesis. The lattice parameters were determined by a least-squares analysis of the 2 θ values for 20 high-angle ($2\theta > 60^\circ$) reflections [at 20°C; $\lambda(\text{Cu } K\alpha_1) = 1.54051 \text{ \AA}$]. The intensities of the 1659 independent reflections with $2\theta < 130^\circ$ were measured on a GE XRD-5 diffractometer by the stationary-counter stationary-crystal technique. The Cu $K\alpha$ radiation was monochromated by balanced nickel and cobalt filters. The crystals were well formed but small and light sensitive and decomposed upon standing. The intensity data used in the structure refinement was collected over a 96 h period from a 0.18 \times 0.12 \times 0.12 mm crystal mounted with its long dimension parallel to the φ axis. Some discoloration in the crystal was noted during data collection, but there were no changes in the intensities of four standard reflections which were measured every hour throughout the experiment. The intensity of the 0,0,30 reflection ($\chi = 90^\circ$, $2\theta = 44^\circ$) varied up to a maximum of 6% from its mean value, and no absorption correction was applied. The usual Lorentz and polarization corrections were applied.

After structure factor amplitudes had been computed, the coordinates of the bromine atom were determined from the Harker section, and two successive Fourier summations revealed the locations of the other non-hydrogen atoms.

The structure was refined by block-diagonal least-squares calculations. During the final least-squares cycles, the positional and anisotropic thermal parameters of the non-hydrogen atoms were refined using all data for which $\sin \theta/\lambda > 0.10$ and $|F_c|/|F_o| > 0.7$. A weighting scheme was chosen so that the values of $\langle w\Delta^2 \rangle$ were invariant with $|F_o|$ where $w^{-1} = \{1 + [(|F_o| - a)/a]^2\}^{1/2}$ and the constant a was taken to be 20e. The quantity minimized was $(\sum w|F_o| - |F_c|)^2 / (m - n)$ where m = the number of reflections and n = the number of parameters refined. Hydrogen atoms ($B_{\text{iso}} = 3.0$) were placed at their theoretical positions and used in the structure factor calculations, but they were not refined. An attempt was made to find the hydrogen atoms on Fourier difference maps, but only a few chemically sensible positions were observed. Refinement of the non-hydrogen atoms was terminated when the calculated shifts in all the parameters were less than $\frac{1}{3}$ their respective standard deviations. The R index, which was defined as $\sum(|F_o| - |F_c|) / \sum|F_o|$, fell to a final value of 12.7% for all 1659 reflections and 8.5% for the 870 reflections having $I > 2\sigma$. The final R values were calculated with the hydrogen atoms included at their computed positions. The final refined parameters of the non-hydrogen atoms are given in

Table 1. Final atomic coordinates and anisotropic thermal parameters for the non-hydrogen atoms

Thermal parameters are of the form $\exp[-2\pi^2(U_{11}h^2a^{*2} + 2U_{12}hka^*b^* + \dots)]$.

The standard deviations of the last two figures are given in parentheses.

	x/a	y/b	z/c	U_{11}	U_{22}	U_{33}	U_{12}	U_{13}	U_{23}
C(1)	0.8546 (27)	1.1784 (28)	-0.0110 (3)	0.044 (8)	0.051 (9)	0.050 (9)	0.018 (7)	-0.019 (7)	0.001 (7)
C(2)	0.8104 (30)	1.2462 (24)	-0.0331 (3)	0.064 (11)	0.029 (7)	0.059 (9)	0.016 (7)	-0.017 (8)	-0.013 (7)
C(3)	0.7282 (24)	1.0629 (26)	-0.0502 (2)	0.030 (7)	0.045 (8)	0.060 (9)	0.010 (6)	0.000 (7)	0.007 (7)
C(4)	0.5970 (31)	0.8589 (26)	-0.0413 (2)	0.071 (11)	0.038 (8)	0.036 (7)	0.023 (8)	0.008 (7)	0.010 (6)
C(5)	0.5572 (22)	0.8143 (23)	-0.0207 (3)	0.024 (6)	0.032 (7)	0.085 (11)	0.014 (6)	-0.028 (7)	-0.016 (7)
C(6)	0.3894 (28)	0.6074 (29)	-0.0121 (2)	0.044 (9)	0.052 (9)	0.040 (7)	0.002 (7)	-0.011 (7)	-0.016 (7)
C(7)	0.4433 (25)	0.5102 (23)	0.0074 (2)	0.039 (8)	0.030 (7)	0.054 (9)	-0.006 (6)	-0.005 (6)	-0.008 (6)
C(8)	0.5585 (26)	0.6820 (21)	0.0255 (2)	0.052 (8)	0.024 (6)	0.043 (7)	0.013 (6)	0.003 (6)	-0.001 (5)
C(9)	0.7451 (21)	0.8796 (21)	0.0156 (2)	0.026 (6)	0.031 (7)	0.041 (7)	0.002 (5)	-0.015 (6)	-0.013 (5)
C(10)	0.6722 (25)	0.9844 (25)	-0.0019 (3)	0.039 (8)	0.041 (8)	0.084 (11)	0.023 (7)	-0.011 (8)	0.002 (8)
C(11)	0.8919 (28)	1.0385 (30)	0.0330 (3)	0.044 (9)	0.051 (10)	0.048 (9)	-0.001 (7)	-0.002 (7)	0.006 (7)
C(12)	0.9498 (25)	0.9316 (26)	0.0514 (3)	0.031 (7)	0.036 (8)	0.078 (11)	-0.010 (6)	-0.003 (7)	0.018 (8)
C(13)	0.7600 (26)	0.7429 (23)	0.0617 (2)	0.044 (8)	0.036 (8)	0.039 (7)	0.004 (6)	-0.001 (6)	-0.001 (6)
C(14)	0.6367 (23)	0.5849 (25)	0.0427 (2)	0.025 (6)	0.043 (8)	0.043 (6)	-0.003 (6)	-0.001 (6)	-0.005 (6)
C(15)	0.4854 (23)	0.3896 (23)	0.0556 (2)	0.032 (7)	0.031 (7)	0.057 (9)	-0.002 (6)	0.001 (6)	0.010 (7)
C(16)	0.5992 (24)	0.3940 (24)	0.0766 (2)	0.036 (7)	0.036 (7)	0.043 (7)	0.009 (6)	0.013 (6)	0.007 (6)
C(17)	0.8072 (24)	0.5996 (25)	0.0765 (2)	0.035 (7)	0.043 (8)	0.049 (9)	0.015 (6)	0.006 (6)	0.002 (7)
C(18)	0.6142 (37)	0.8147 (29)	0.0749 (3)	0.097 (14)	0.049 (9)	0.044 (9)	0.043 (10)	0.011 (9)	-0.007 (7)
C(19)	0.4968 (36)	1.0239 (40)	0.0072 (3)	0.070 (13)	0.083 (14)	0.082 (15)	0.054 (12)	-0.019 (11)	-0.016 (11)
C(20)	0.8810 (27)	0.6925 (28)	0.0997 (2)	0.052 (9)	0.058 (9)	0.022 (5)	0.017 (7)	-0.012 (6)	0.000 (6)
C(21)	1.1186 (30)	0.8487 (31)	0.1016 (3)	0.057 (10)	0.054 (10)	0.047 (9)	0.011 (8)	0.005 (8)	0.000 (8)
O(3)	0.7405 (24)	1.0999 (22)	-0.0696 (2)	0.079 (9)	0.060 (8)	0.062 (7)	0.016 (7)	-0.013 (7)	0.011 (6)
O(11)	0.7996 (25)	1.1565 (18)	0.0414 (2)	0.093 (10)	0.032 (6)	0.073 (7)	0.023 (6)	0.016 (7)	-0.009 (5)
O(17)	0.9749 (19)	0.5758 (20)	0.0663 (1)	0.050 (6)	0.070 (7)	0.036 (5)	0.031 (6)	0.009 (5)	0.003 (5)
O(20)	0.7689 (20)	0.6429 (23)	0.1148 (2)	0.054 (7)	0.075 (8)	0.055 (7)	0.030 (7)	0.012 (5)	-0.003 (6)
O(21)	1.1568 (24)	0.9235 (25)	0.1241 (2)	0.069 (9)	0.079 (10)	0.047 (7)	0.009 (7)	-0.021 (6)	-0.021 (6)
Br	0.9280 (2)	0.7903 (3)	0.0000 (1)	0.047 (1)	0.067 (1)	0.049 (1)	0.031 (1)	0.009 (1)	0.009 (1)

Table 1, and a list of the structure factors is obtainable.*

Discussion

The interatomic distances and valency angles for 9 α -bromocortisol, which are presented in Fig. 1, are normal with the exception of the long C(13)–C(18) distance. The carbon–bromine distance of 2.02 Å agrees with the value of 2.028 Å observed in 9 α -bromo-17 β -hydroxy-17 α -methylandro-4-ene-3,11-dione (Cooper, Lu & Norton, 1968). The standard deviations of the distance and angle measurements are in the ranges 0.014–0.029 Å and 0.8–1.9°, respectively.

As shown by the intraring torsional angles in Fig. 2, the *A*-ring has a half-chair conformation, and the *B* and *C*-rings have chair conformations. The *D*-ring conformation is intermediate between a half-chair and a *C*(13) or β -envelope, but more nearly a β -envelope as shown by the parameters $\Delta = 25.9$ and $\varphi_m = 47.5$ (Altona, Geise & Romers, 1968). The C(17) side chain orientation, which may be observed in Fig. 1, closely resembles the orientation in similar structures (Weeks, Duax & Wolff, 1973). The torsion angles about the C(17)–C(20) bond are given in the Newman projection (Fig. 3). The non-hydrogen atoms in the side chain are nearly coplanar [torsional angle O(20)–C(20)–C(21)–O(21) = -4.8°], and the C(20)–O(20) and C(21)–O(21) bonds have a *cis* orientation which places O(21) at a maximum distance from O(17).

As shown in Table 2, there are few close intermolecular contacts. Hydrogen bonds (2.90 Å) between O(3) and O(17) join symmetry-related molecules which form spirals about the screw axes. Weak hydrogen bonds (3.09 Å) between O(11) and O(17) join translationally related molecules and form rows perpendicular to the symmetry axis. There is no hydrogen bond

* This table has been deposited with the National Lending Library, England, as Supplementary Publication No. SUP 30111. Copies may be obtained through the Executive Secretary, International Union of Crystallography, 13 White Friars, Chester CH1 1NZ, England.

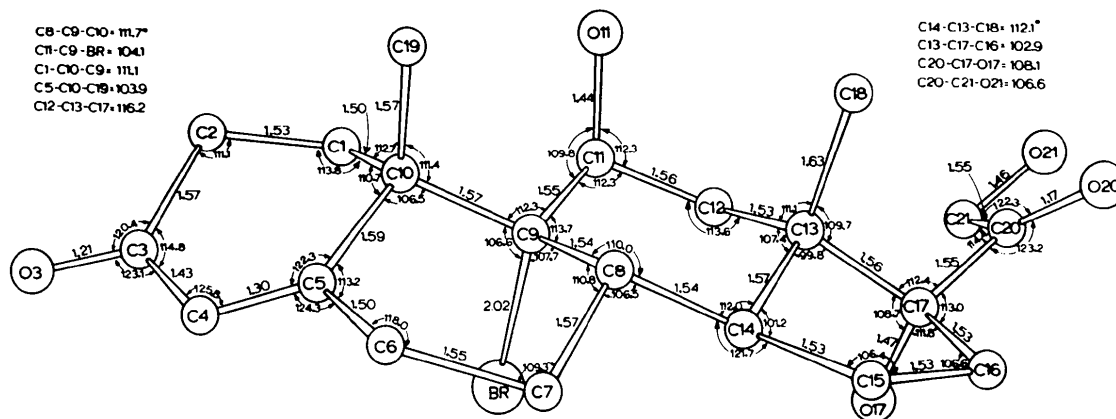

Fig. 1. Interatomic distances and valency angles in 9 α -bromocortisol. The standard deviations of the distance and angle measurements are in the ranges 0.014–0.029 Å and 0.8–1.9°, respectively.

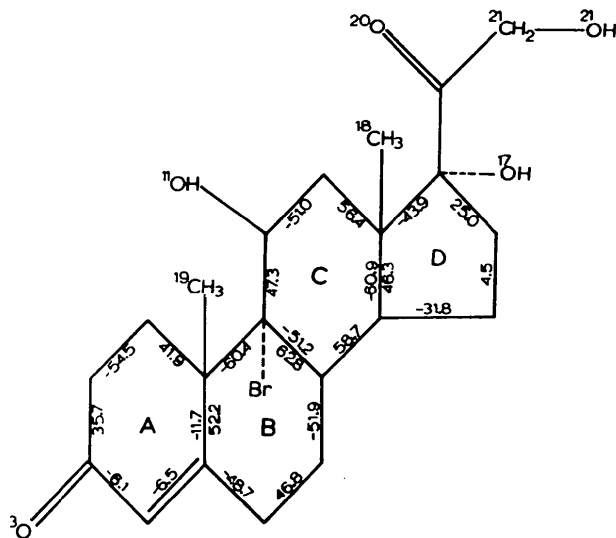

Fig. 2. Torsional angles in the rings. Each torsional angle is centered about the bond on which the number is placed, and the other two atoms required to define the angle are attached to either end of the bond and are in the ring in question. The sign convention for the angles is that of Klyne & Prelog (1960).

involving the O(21) hydroxyl group. One view of the hydrogen bonds and the molecular stacking is given in Fig. 4.

Table 2. Intermolecular non-hydrogen distances less than 3.5 Å

The equivalent positions are $1 = (x, y, z)$ and $2 = (y, y - x, \frac{1}{2} + z)$. The notation 2/010 means that the second atom is at equivalent position 2, translated one unit cell in the *b* direction.

Atom 1	Atom 2	Distance	Position
C(20)	C(4)	3.48 Å	2/000
O(11)	O(17)	3.09	1/010
O(17)	O(3)	2.90	2/000
O(20)	C(4)	3.26	2/000
O(21)	C(1)	3.47	2.010
O(21)	C(3)	3.46	2/010
O(21)	C(6)	3.47	2/110

The glucocorticoid activity of cortisol may be increased by 9α -fluorination, but activity is decreased by substitution of a bromine atom at the 9-position (Fried, 1961). The structure of 9α -bromocortisol was determined in order that the detailed geometry of the molecule might be compared to that of cortisol (Rob-

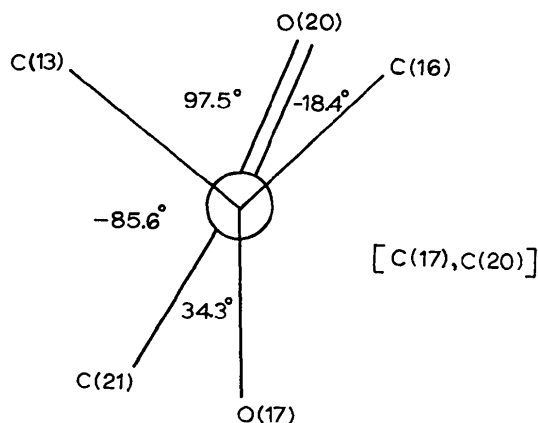

Fig. 3. Newman projection down the C(17)-C(20) bond.

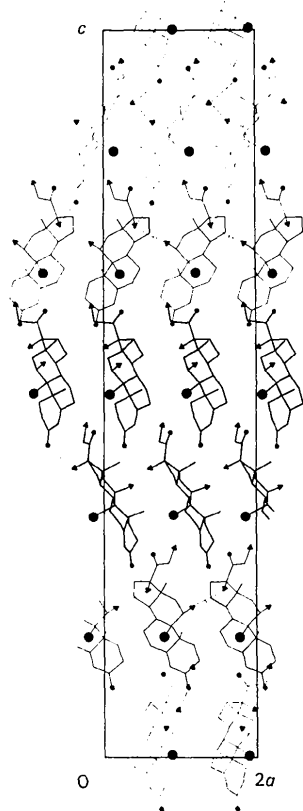

Fig. 4. Molecular packing as seen in projection onto the (010) plane. ● = Bromine, ● = carbonyl oxygen, and ▲ = hydroxyl oxygen.

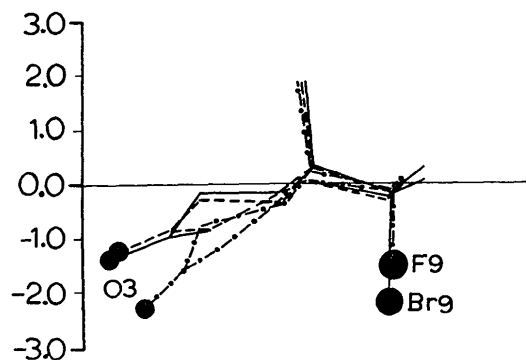

Fig. 5. The *A* and *B*-rings of cortisol (---), 9α -bromocortisol (—), and 9α -fluorocortisol (-·-·) are shown projected parallel to a plane passed through the *B*, *C*, and *D*-rings [atoms C(5) to C(17) inclusive].

erts, personal communication) and 9α -fluorocortisol (Weeks & Duax, 1972; Dupont, Dideberg & Campsteyn, 1972). The conformations of these molecules are similar except for the orientations of the *A*-rings with respect to the rest of the steroid nucleus. As shown in Fig. 5, the *A*-ring in 9α -fluorocortisol is bent underneath the plane of the *B*, *C*, and *D*-rings to a much greater extent than it is in cortisol and 9α -bromocortisol, and the enhanced biological activity of 9α -fluorocortisol may be related, in part, to this conformational difference. However, the reduced activity of 9α -bromocortisol appears to result from the presence of the bulky bromine atom itself since there are no significant changes in the ring conformations.

The authors wish to thank Dr Manfred Wolff and Don Giannini for synthesis and crystallization of the sample of 9α -bromocortisol. This research was supported by U.S.P.H. Grant No. CA 10906.

References

- ALTONA, C., GEISE, H. J. & ROMERS, C. (1968). *Tetrahedron*, **24**, 13-32.
- COOPER, A., LU, C. T. & NORTON, D. A. (1968). *J. Chem. Soc. (B)*, pp. 1228-1237.
- DUPONT, L., DIDEBERG, O. & CAMPSTEYN, H. (1972). *Acta Cryst. B* **28**, 3023-3032.
- FRIED, J. (1961). *Biological Activities of Steroids in Relation to Cancer*, pp. 9-23. Edited by G. PINCUS and E. P. VOLLMER. New York: Academic Press.
- KLYNE, W. & PRELOG, V. (1960). *Experientia*, **16**, 521.
- KOLLMAN, P. A., GIANNINI, D., DUAX, W. L., ROTHENBERG, S. & WOLFF, M. E. (1973). *J. Amer. Chem. Soc.* **95**, 2869-2873.
- WEEKS, C. M. & DUAX, W. L. (1972). Abstract M5, Amer. Cryst. Assoc. Meeting, Albuquerque, N. M.
- WEEKS, C. M., DUAX, W. L. & WOLFF, M. E. (1973). *J. Amer. Chem. Soc.*, **95**, 2865-2868.
- ZANATI, G. & WOLFF, M. E. (1971). *J. Med. Chem.* **14**, 958-961.